



The SATORI project

Stakeholders Acting Together on the ethical
assessment of
Research and Innovation

PHILIP BREY, PROJECT COORDINATOR

Aim of SATORI

Development of a framework of common principles, protocols, procedures and best practices for the ethical assessment and guidance of research and innovation in the European Union and beyond.

Structure of SATORI

▶ Three stages

Fact-finding stage	Framework construction stage	Elaboration and communication stage
Month 1-19	Month 20-35	Month 36 – 45
WP 1, 2, 3	WP 4, 5, 6	WP 7, 8, 9, 10

- ▶ **WP 1-10:** Substantive work packages
- ▶ **WP 11:** Coordination
- ▶ **WP 12:** Evaluation

The SATORI Team

Participant no.	Participant organisation name	Partner short form	Country
1	University of Twente	UT	Netherlands
2	De Montfort University	DMU	UK
3	Trilateral Research Ltd	TRI	UK
4	Danish Board of Technology	DBT	Denmark
5	Center for the Promotion of Science	CPS	Serbia
6	European Union of Science Journalists' Association	EUSJA	France
7	Helsinki Foundation for Human Rights	HFHR	Poland
8	VTT Technical Research Centre of Finland	VTT	Finland
9	NEN (Netherlands Standardization Agency)	NEN	Netherlands
10	Italian Association for Industrial Research (Associazione Italiana Per La Ricerca Industriale)	AIRI	Italy

The SATORI Team

11	Instituto de Salud Carlos III (Research Ethics Committee) (until 2016)	ISCIII	Spain
12	Scientific Research Centre of the Slovenian Academy of Sciences and Arts	ZRC SAZU	Slovenia
13	United Nations Educational, Scientific and Cultural Organization	UNESCO	France
14	Linköping University	LIU	Sweden
15	Ericsson Telecomunicazioni SpA	ET	Italy
16	Institute for Advanced Studies	IHS	Austria
17	Danish Standards	DS	Denmark

Some terminology...

Ethics Assessment

Any kind of assessment, evaluation, review, appraisal or valuation of practices, products and uses of research and innovation that makes use of primarily ethical principles or criteria

- ▶ “The proposed experiment does not live up to standards of informed consent.”
- ▶ “Web browsers that place cookies violate privacy.”

Additional Requirements

- ▶ The framework should include all scientific disciplines.

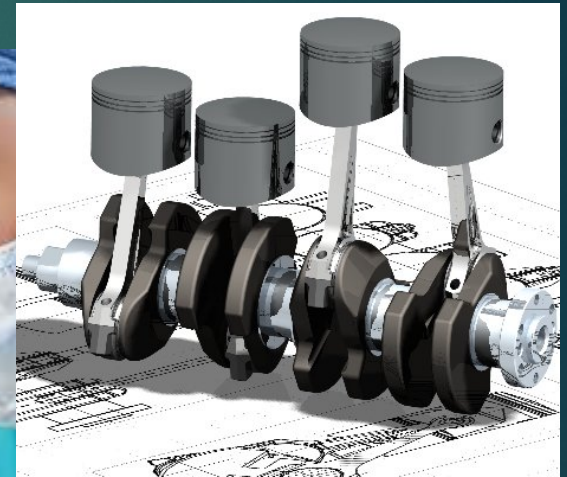
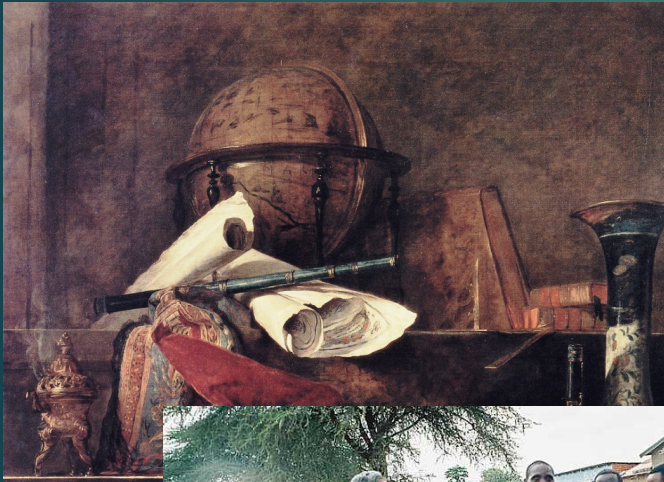

Additional Requirements

- ▶ **Mutual learning**



Additional Requirements

- ▶ Stakeholder and public engagement



Additional Requirements

- ▶ **Balancing uniformity and diversity**



Additional Requirements

Usefulness to a wide variety of ethics assessors



Main results and recommendations

Objectives

- ▶ Developing recommendations and guidelines for ethics assessment and guidance for EU member states
 - ▶ in general
 - ▶ for specific kinds of organizations, fields and purposes
- ▶ Developing an approach for ethical impact assessment
- ▶ Developing recommendations for the general institutional structure of ethics assessment in the EU and its member states.

Dozens of reports on:

- ▶ How ethics assessment and guidance are currently practiced in the EU and beyond
 - ▶ In different countries, and at EU and international level
 - ▶ In different fields
 - ▶ By different types of organisations
(e.g., universities, industry, CSOs, research funding organisations, governmental organisations)
- ▶ How ethics assessment could be improved
 - ▶ What organisations see as current flaws
 - ▶ Standards and best practices for different organisations, fields, etc.

- ▶ Recommendations for the institutional structure of ethics assessment in the EU and its member states and for supporting policies

Policy Brief 1: Supporting ethics assessment in research and innovation

Towards a support system for ethics assessment

- Regulatory framework
- Standards, monitoring and oversight
- National bodies
- Support for discussion, training, awareness
- Many organisations have a role

Policy Brief 2:

Improving the organisation of research ethics committees (RECs)

- Proper governance of RECs
 - (Guidelines for composition, appointment process, training)
- Harmonization of procedures for RECs
- Ensuring quality control for RECs
- Adequate funding for these improvements

Policy Brief 2:

Improving the organisation of research ethics committees (RECs)

- Proper governance of RECs
 - (Guidelines for composition, appointment process, training)
- Harmonization of procedures for RECs
- Ensuring quality control for RECs
- Adequate funding for these improvements

Policy Brief 3

Ethical Impact Assessment (EIA)

Focus on (possible) ethical impacts of R&I

Ethical impact = impact with ethical aspects

EIA as a tool for social responsibility in R&I